

INSTALLATION INSTRUCTIONS

# SILVER C RX/PX/CX



EN - Installation instructions  
SE - Installationsanvisning  
DE - Installationsanleitung  
FR - Instructions d'installation  
NO - Installasjonsanvisning  
DK - Installationsanvisning  
FI - Asennusohje  
PL - Instrukcja instalacji  
RU - Инструкция по установке и монтажу  
ES - Instrucciones de instalación  
IT - Istruzioni per l'installazione  
PT - Instruções de instalação  
NL - Installatieaanwijzing

# CONTENTS

The document was originally written in Swedish.

## EN - CONTENTS

1. Key to symbols	4
2. Lifting	5
3. Unpacking	6
4. Serial number	6
5. Splitting/Installation of air handling unit sections	7
6. Placement	8-9
7. Water trap	10
8. Connection to the Ducting	11-12
9. Electrical Connections	13
10. Airflow direction	13

## NO - INNHOLDSFORTEGNELSE

1. Tegnforklaring	4
2. Løfte	5
3. Oppakning	6
4. Serienummer	6
5. Deling/montering av aggregatseksjoner	7
6. Plassering	8-9
7. Vannlås	11
8. Tilkobling kanaler	11-12
9. El-tilkobling	13
10. Luftretning	13

## SE - INNEHÅLLSFÖRTECKNING

1. Teckenförklaring	4
2. Lyft	5
3. Uppackning	6
4. Serienummer	6
5. Delning/Montage av aggregatsektioner	7
6. Placering	8-9
7. Vattenlås	10
8. Anslutning kanaler	11-12
9. Elanslutning	13
10. Luftriktning	13

## DK - INHOLDSFORTEGNELSE

1. Tegnforklaring	4
2. Løfte	5
3. Udpakning	6
4. Serienummer	6
5. Deling/Montering af aggregatsektioner	7
6. Placering	8-9
7. Vandlås	10
8. Tilslutning, kanaler	11-12
9. El-tilslutning	13
10. Luftretning	13

## DE - INHALTSVERZEICHNIS

1. Zeichenerklärung	4
2. Anheben	5
3. Auspacken des Zubehörs	6
4. Seriennummer	6
5. Zerlegung/Montage von Gerätesektionen	7
6. Innenaufstellung	8-9
7. Siphon	10
8. Anschluss Kanäle	11-12
9. Elektroanschluss	13
10. Luftrichtung	13

## FI - SISÄLLYSLUETTELO

1. Merkkien selitys	4
2. Nostaminen	5
3. Pakkauksen purkaminen	6
4. Sarjanumero	6
5. Koneen osien erottaminen/yhdistäminen	7
6. Sijoitus	8-9
7. Vesilukko	10
8. Kanavaliitäntä	11-12
9. Tehonsyöttöliitäntä	13
10. Ilmavirran	13

## FR - TABLE DE MATIÈRES

1. Explication des symboles	4
2. Levage	5
3. Déballage	6
4. Numéro de série	6
5. Désassemblage/Assemblage des sections d'une centrale de traitement d'air	7
6. Positionnement	8-9
7. Siphon	10
8. Raccordement canaux	11-12
9. Raccordement électrique	13
10. Sens de circulation de l'air	13

## PL - SPIS TREŚCI

1. Oznaczenia symboli	4
2. Transport pionowy	5
3. Rozpakowanie-części składowe centrali	6
4. Numery seryjne	6
5. Podział/Montaż sekcji centrali	7
6. Posadowienie centrali	8-9
7. Syfon wodny	10
8. Podłączenie przewodów powietrza	11-12
9. Włącznik główny	13
10. Zmiana kierunku przepływu powietrza	13

# CONTENTS

## RU - Оглавление

1. Обозначения	4
2. Подъем краном	5
3. Распаковывание	6
4. Серия-номер	6
5. Разделение/Монтаж секций агрегата	7
6. Установка	8-9
7. Водяной затвор	10
8. Присоединение	11-12
9. Подключение питания	13
10. Изменение направления воздуха	13

## PT - ÍNDICE

1. Explicação de símbolos	4
2. Levantar	5
3. Desembalagem	6
4. Número de série	6
5. Divisão/instalação de secções de unidades	7
6. Colocação	8-9
7. Sifão	10
8. Ligação canais	11-12
9. Ligação eléctrica	13
10. Direcção do ar	13

## ES - ÍNDICE

1. Explicación de los símbolos	4
2. Elevación	5
3. Desembalaje	6
4. Número de serie	6
5. División/instalación de secciones de la unidad de tratamiento de aire	7
6. Ubicación	8-9
7. Colector de agua	10
8. Conductos de conexión	11-12
9. Conexión eléctrica	13
10. Dirección del aire	13







## NL - INHOUDSOPGAVE

1. Legenda	4
2. Het opheffen	5
3. Uitpakken	6
4. Serienummer	6
5. Verdeling/installatie van secties van de luchtbehandelingsunit	7
6. Plaatsing	8-9
7. Sifon	10
8. Aansluiten kanalen	11-12
9. Aansluiten	13
10. Luchtrichting	13

## IT - INDICE

1. Legenda	4
2. Sollevamento	5
3. Disimballaggio	6
4. Numero di serie	6
5. Suddivisione/installazione sezioni delle unità di trattamento dell'aria	7
6. Posizionamento	8-9
7. Sifone	10
8. Collegamento dei canali	11-12
9. Collegamenti elettrici	13
10. Direzione dell'ariai	13

1.

					
<b>EN</b> Warning	Protect from moisture	Outdoor air	Supply air	Extract air	Exhaust air
<b>SE</b> Varning	Skyddas från väta	Uteluft	Tilluft	Frånluft	Avluft
<b>DE</b> Warnung	Vor Nässe schützen	Außenluft	Zuluft	Abluft	Fortluft
<b>FR</b> Avertissement	Protéger contre l'humidité	Air extérieur	Air de pulsion	Air extrait	Air rejeté
<b>NO</b> Advarsel	Beskyttes fra væte	Uteluft	Tilluft	Avtrekksluft	Avkast
<b>DK</b> Advarsel	Beskyttes mod væde	Friskluft	Indblæsningsluft	Udsugningsluft	Afgangsluft
<b>FI</b> Varoitus	Suojattava kastumiselta	Ulkoilma	Tuloilma	Poistoilma	Jäteilma
<b>PL</b> Uwaga!	Chronić przed wilgocią	Powietrze zewnętrzne	Powietrze nawiewane	Powietrze wywiewane	Powietrze wyrzucane
<b>RU</b> Внимание	Защитить от влаги	Наружный воздух	Приточный воздух	Отработанный воздух	Вытяжной воздух
<b>ES</b> Advertencia	Proteger contra la humedad	Aire exterior	Aire de impulsión	Aire de retorno	Aire de extracción
<b>IT</b> Avvertenza	Teme l'umidità	Aria esterna	Aria in entrata	Aria in uscita	Sfiato
<b>PT</b> Aviso	Proteger contra a humidade	Ar exterior	Ar de entrada	Ar de saída	Ar de extracção
<b>NL</b> Waarschuwing	Tegen vocht beschermen	Buitenlucht	Inlaatlucht	Uitlaatlucht	Afvoerlucht



SILVER C 004/005, 007/008, 011/012, 014/020, 025/030, 035/040, 050/060, 070/080

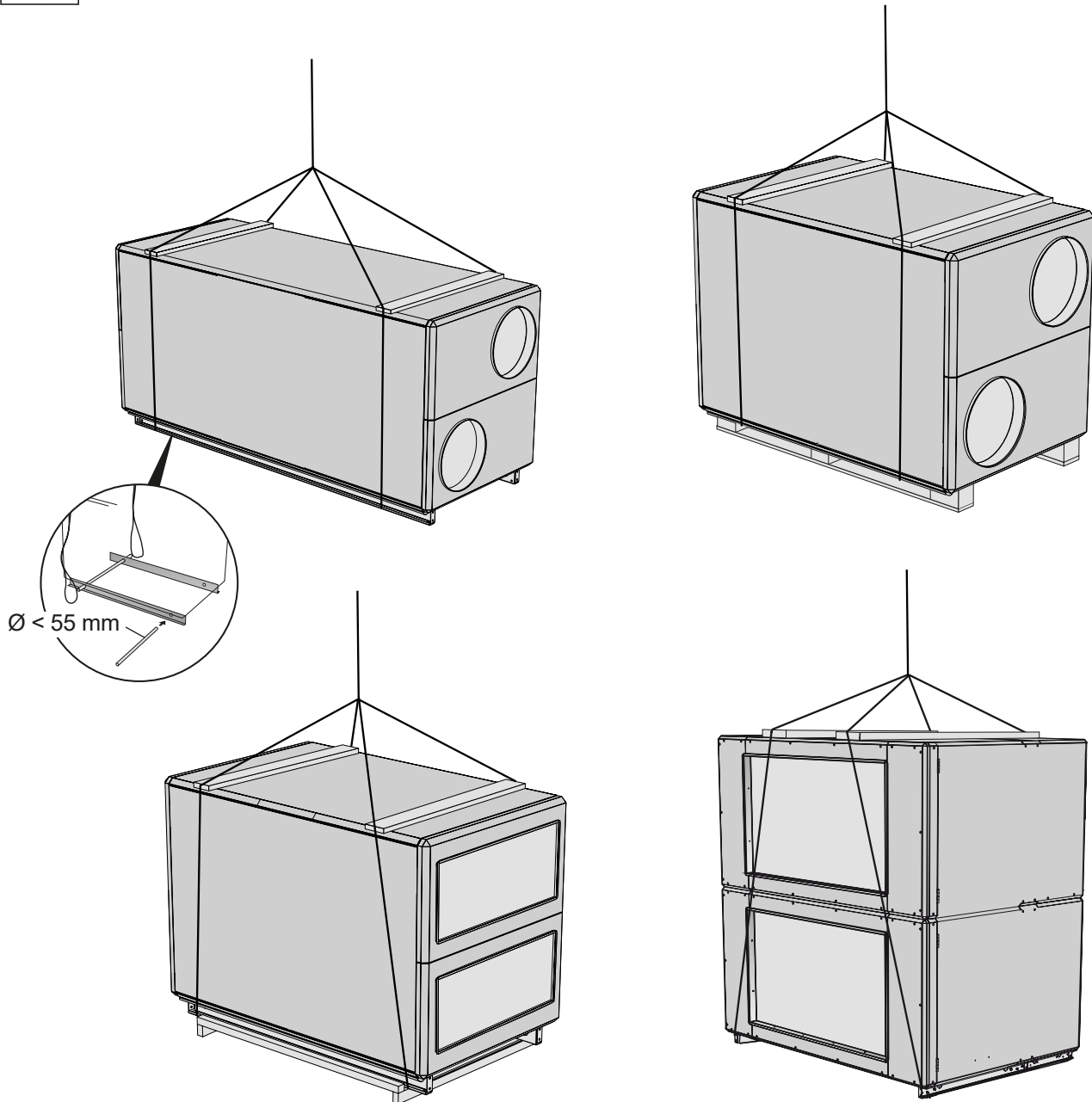

- EN - For weights, see the relevant package
- SE - För vikter, se respektive kolli
- DE - Für Gewichte siehe jeweilige Verpackung
- FR - Les poids figurent sur les emballages correspondants.
- NO - For vekt se respektive kolli
- DK - Se det pågældende kolli for vægtoplysninger
- FI - Katso painot vastaavista kolleista
- PL - Waga, patrz odpowiednie sekcje.
- RU - Вес, см. на упаковке
- ES - Consulte los pesos en el paquete correspondiente
- IT - Per i pesi, vedere il relativo pacchetto
- PT - Para os pesos, ver o equipamento relevante
- NL - Voor gewichten, zie het relevante pakket

3.

SILVER C004/005, 007/008, 011/012, 014/020, 025/030, 035/040, 050/060, 070/080

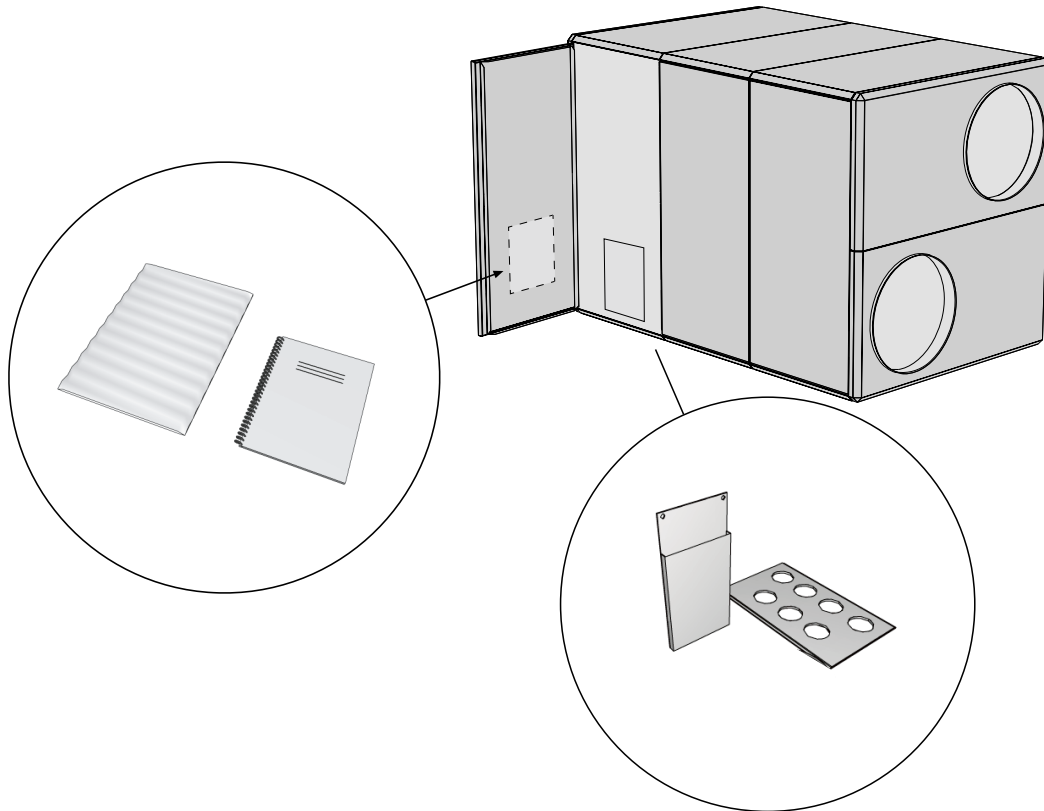

4.

SILVER C 004/005, 007/008, 011/012, 014/020, 025/030, 035/040

SILVER C 050/060, 070/080

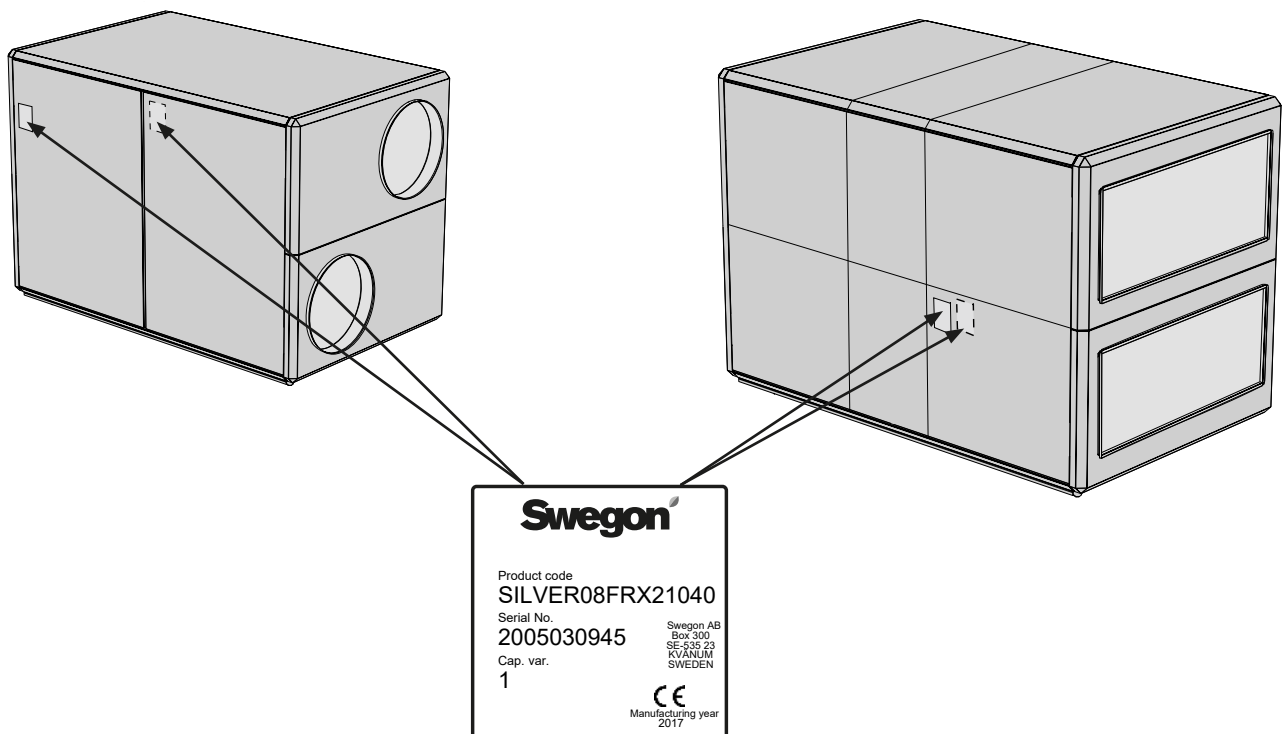

SILVER C 004/005, 007/008, 011/012, 014/020, 025/030 ●  
SILVER C 035/040, 050/060 ●♻️  
SILVER C 070/080 ●♻️●

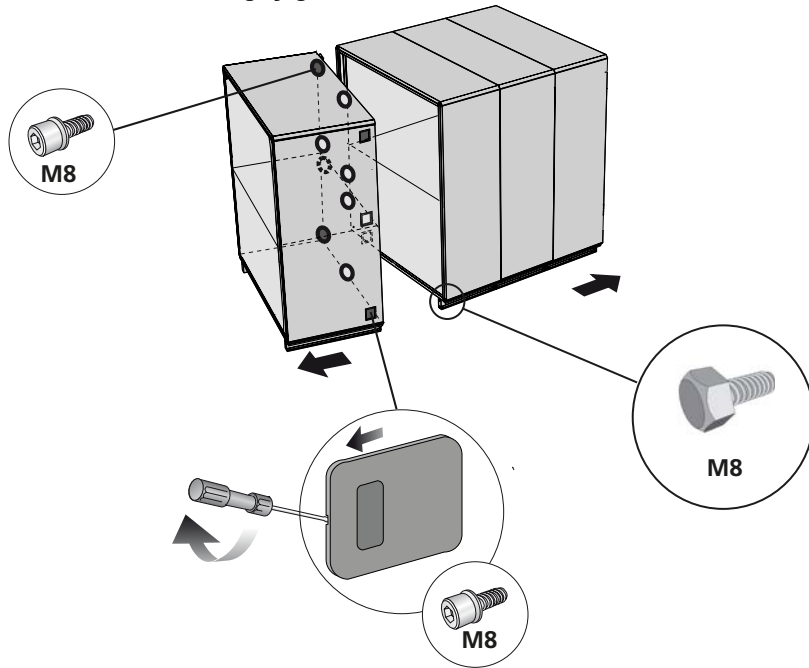

Alt. 1

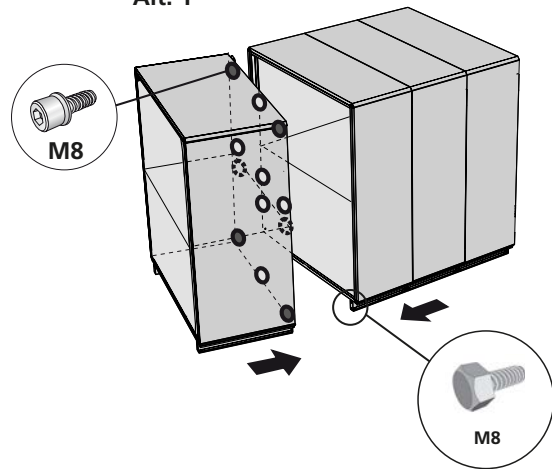

Alt. 2

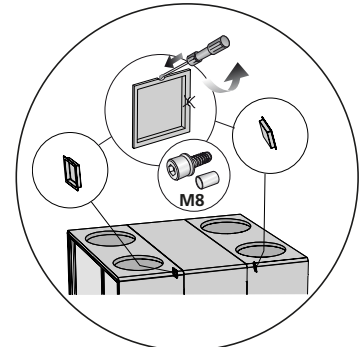
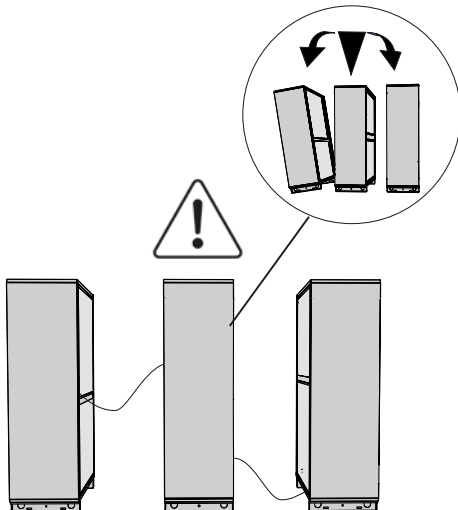
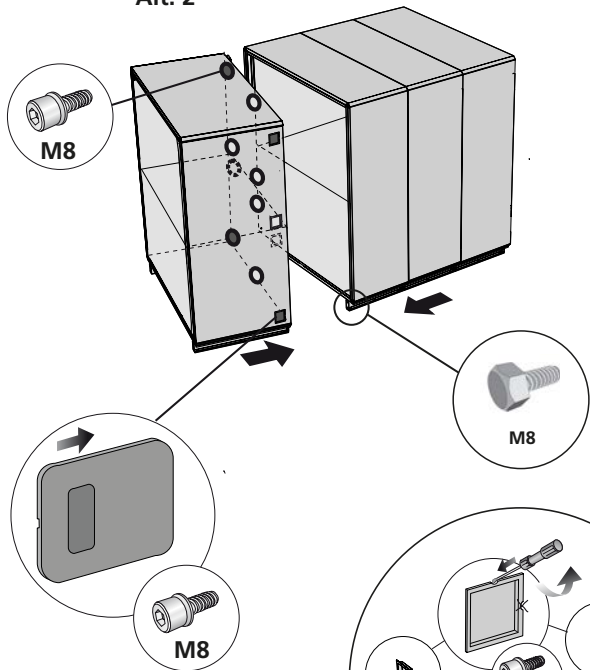

SILVER C RX Top 012

**SILVER C RX 004/005, 007/008**

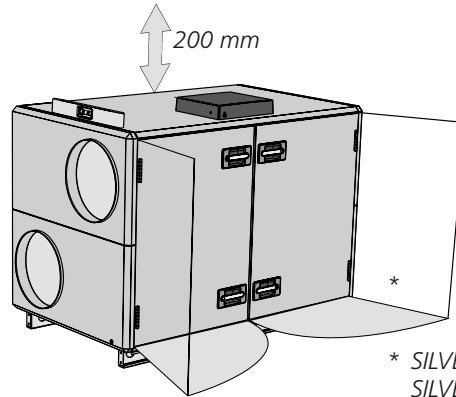
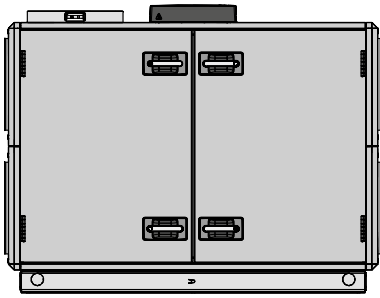

\* SILVER C RX 004/005 = 800 mm  
SILVER C RX 007/008 = 900 mm

**SILVER C PX 004/005, 007/008**

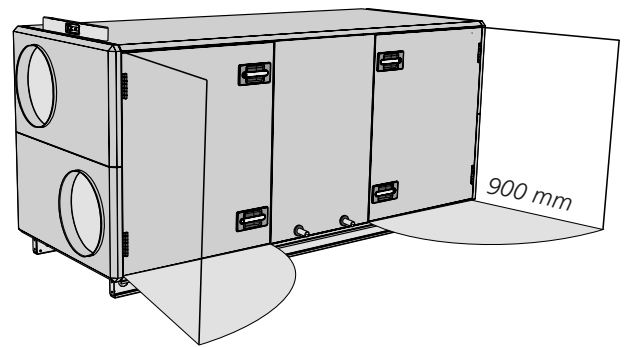
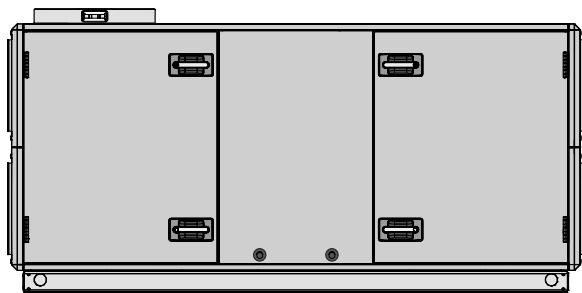

**SILVER C 011/012, 014/020**

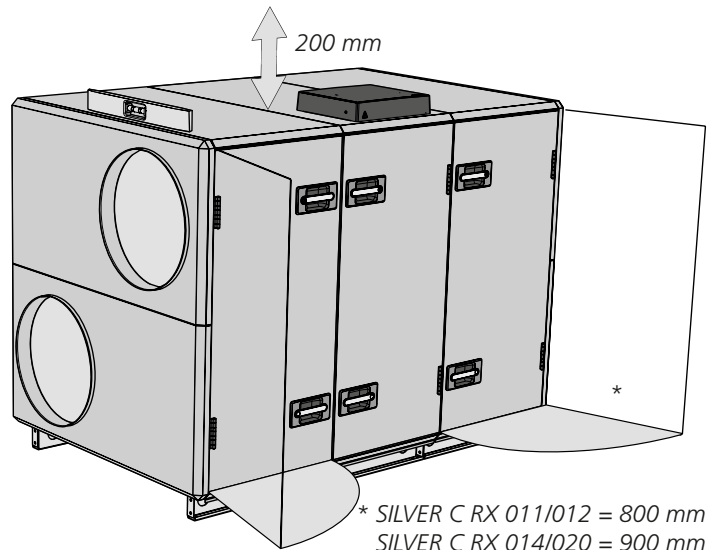
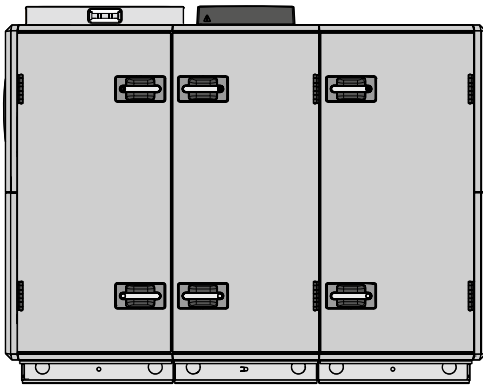

\* SILVER C RX 011/012 = 800 mm  
SILVER C RX 014/020 = 900 mm  
SILVER C PX 011/012, 014/020 = 900 mm  
SILVER C RX/PX Top 014/020 = 1000 mm

**SILVER C 025/030**

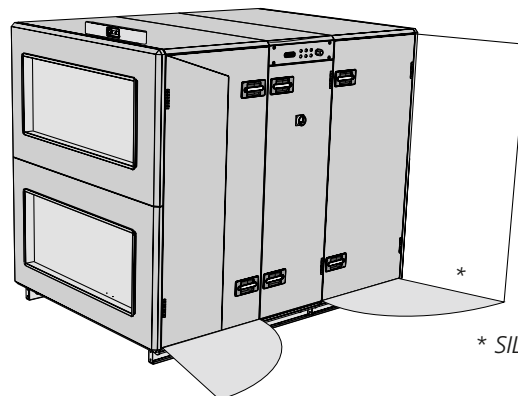
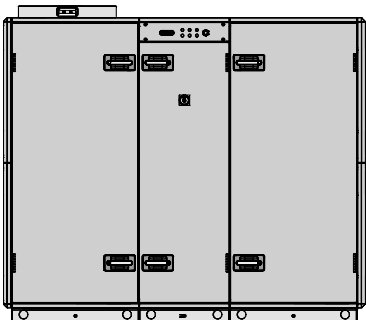

\* SILVER C RX/PX 025/030 = 900 mm  
SILVER C RX 014/020 = 900 mm



SILVER C 035/040

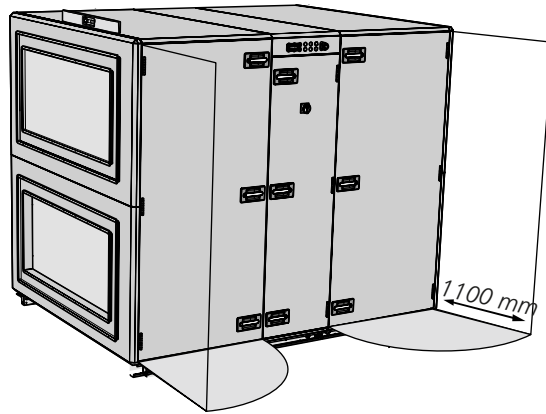
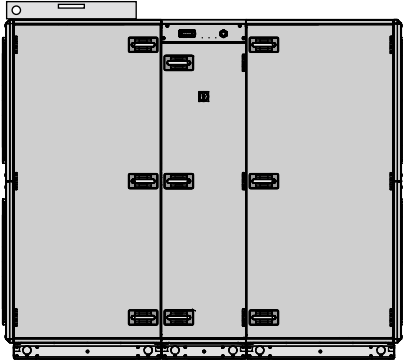

SILVER C 050/060

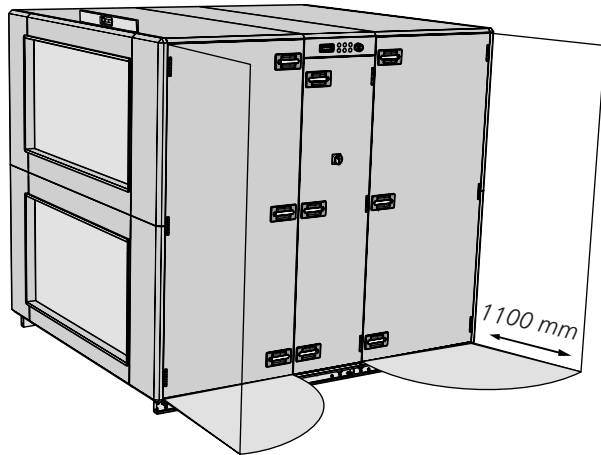
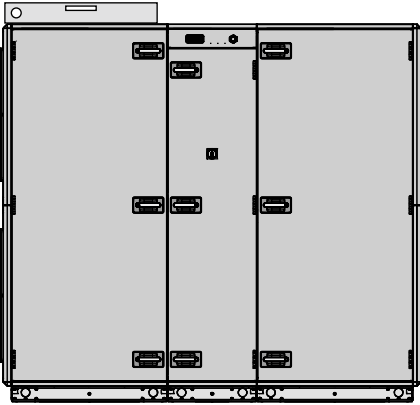

SILVER C 070/080

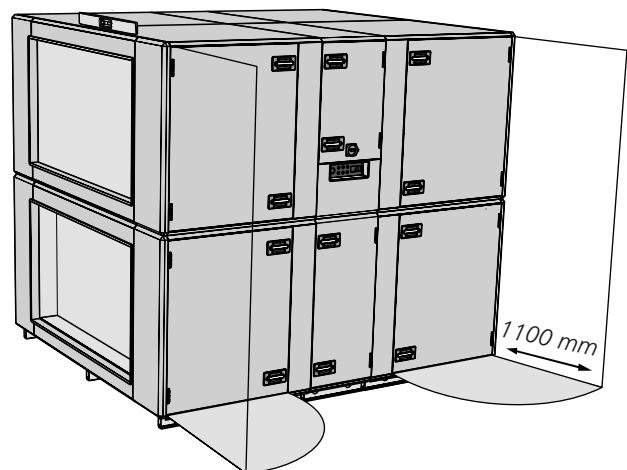
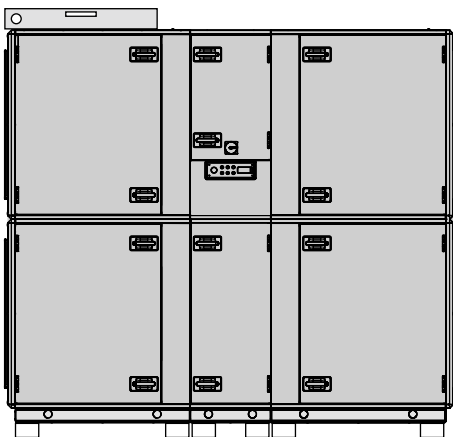

## SILVER C PX/CX

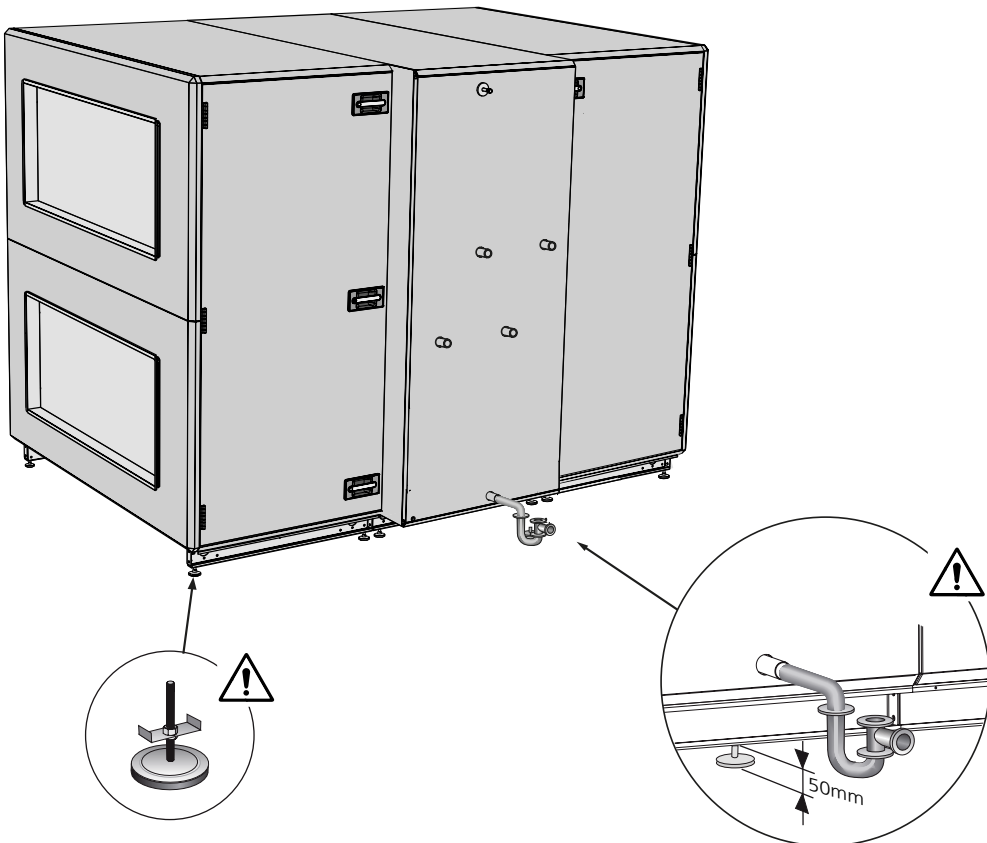
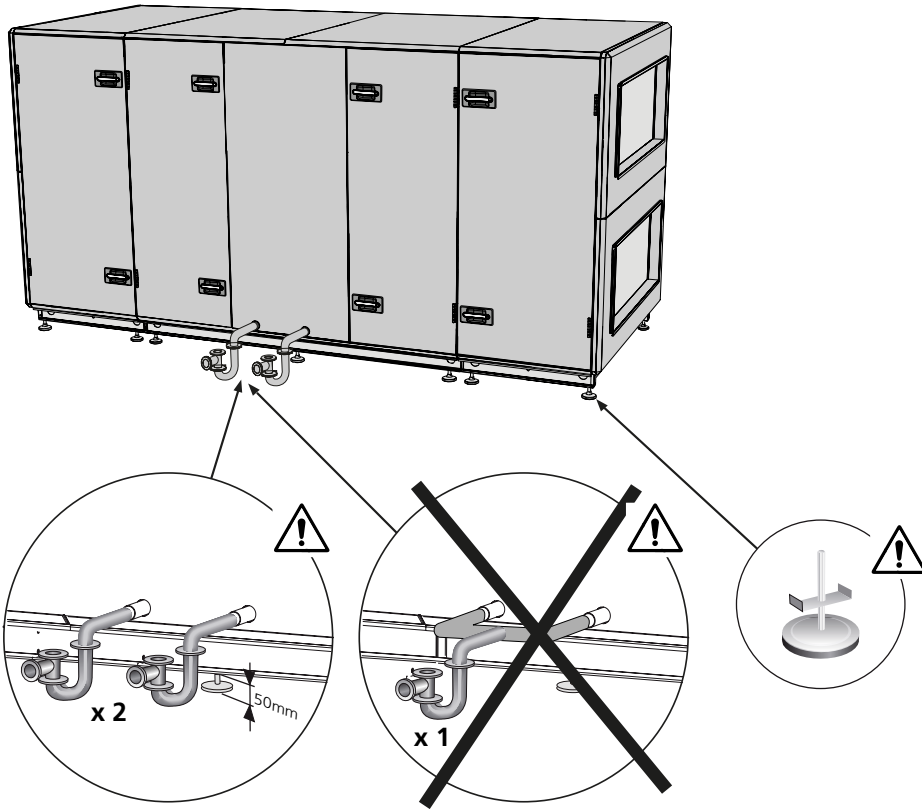

SILVER C 004/005, 007/008, 011/012

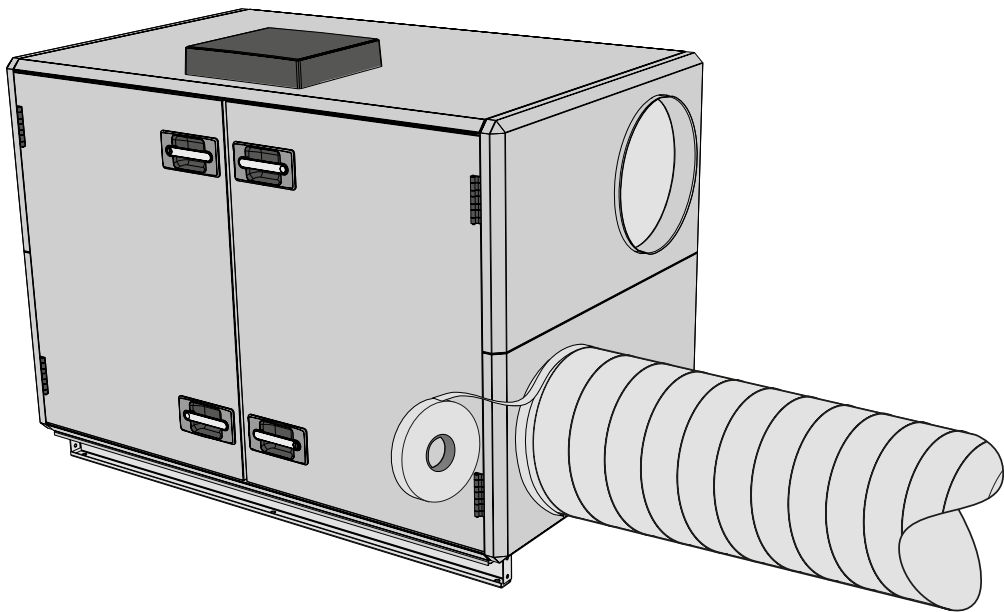
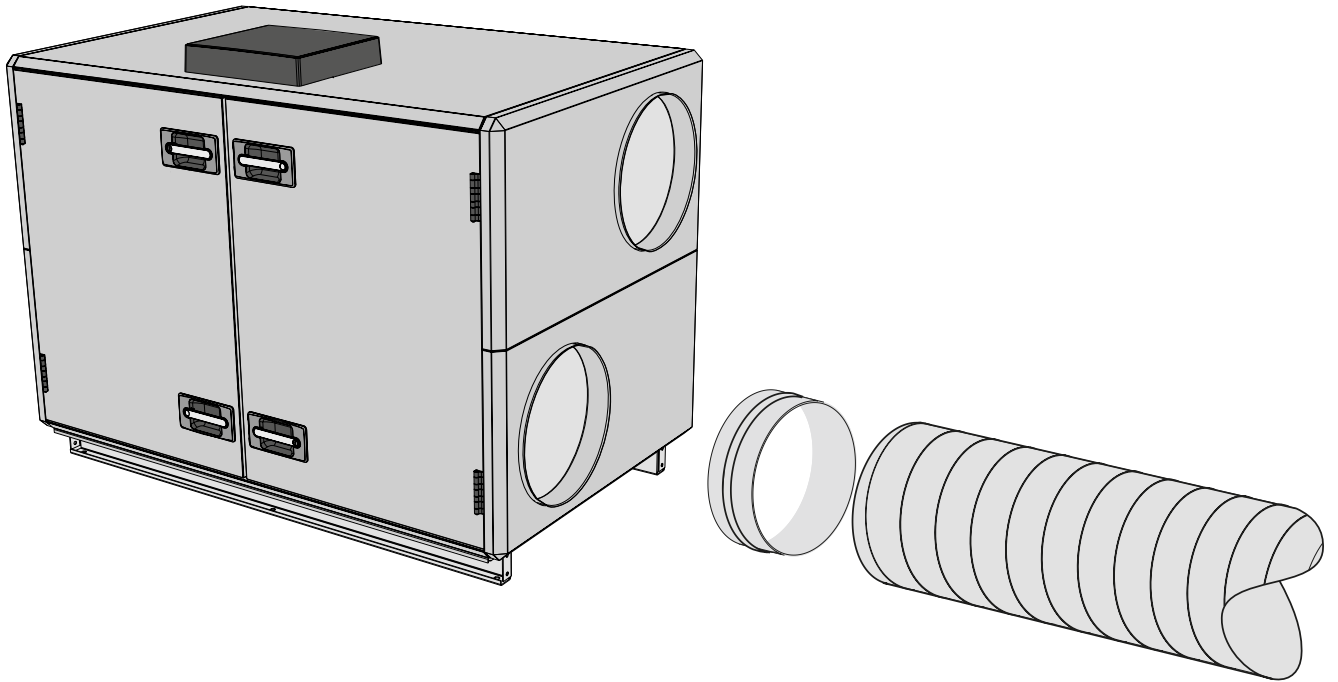

SILVER C 014/020, 025/030, 035/040, 050/060, 070/080

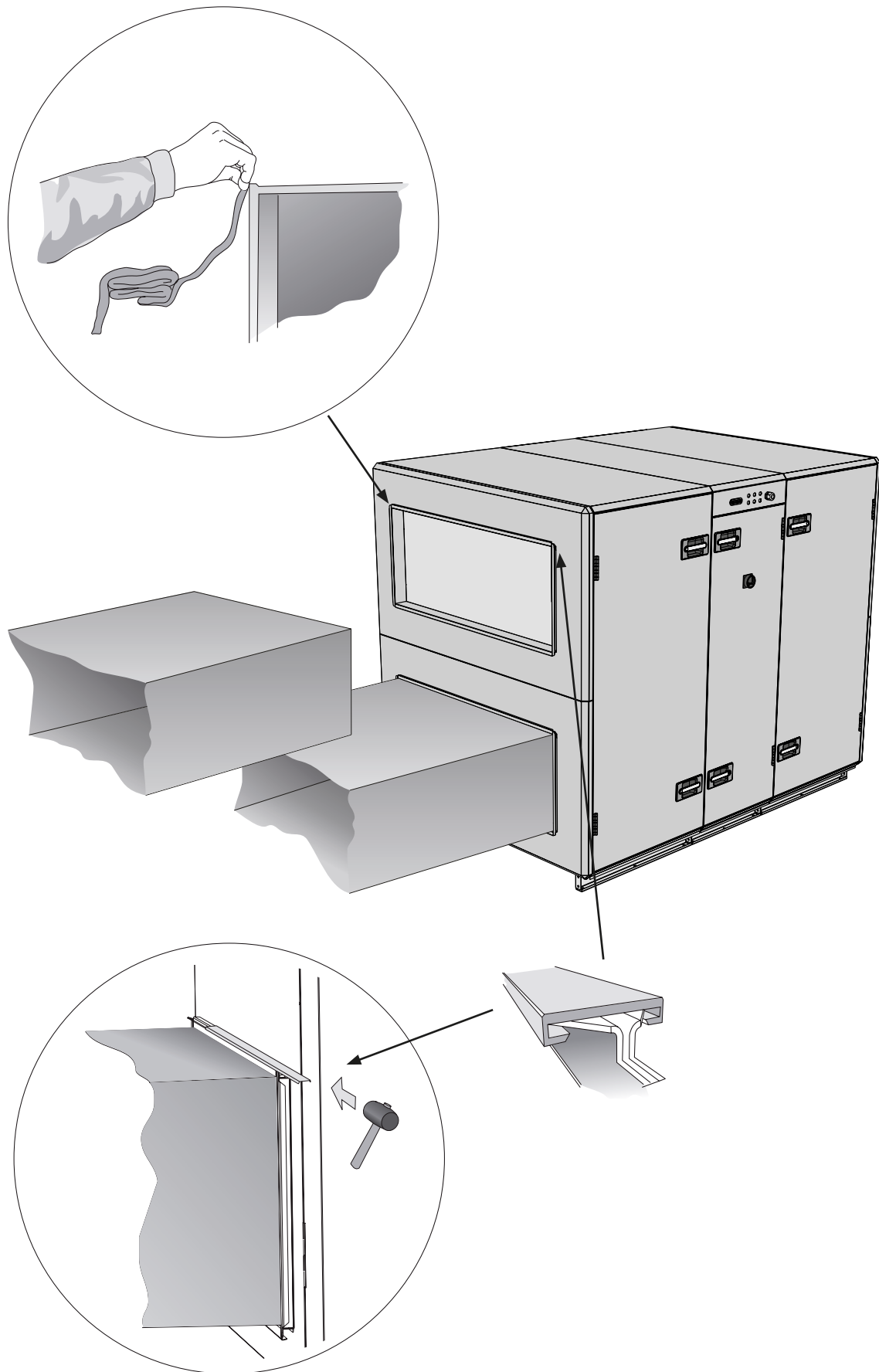

## 9.

EN - See special instructions for electrical connection of fan motors, heat exchanger controls, damper actuators etc.  
SE - Se särskilda instruktioner för elektrisk anslutning av fläktmotorer, värmeväxlarstyrning, spjällmotorer etc.  
DK - Se separat vejledning til elektrisk tilslutning af ventilatormotorer, varmevekslerstyrning, spjældmotorer osv.  
FI - Katso puhallinmoottorien, lämmösiirrinohjaimen, peltitoimilaitteiden jne. sähköliitännöjen erilliset ohjeet.

## 10.

**SILVER C RX 004/005, 007/008, 011/012, 014/020, 025/030, 035/040, 050/060, 070/080**

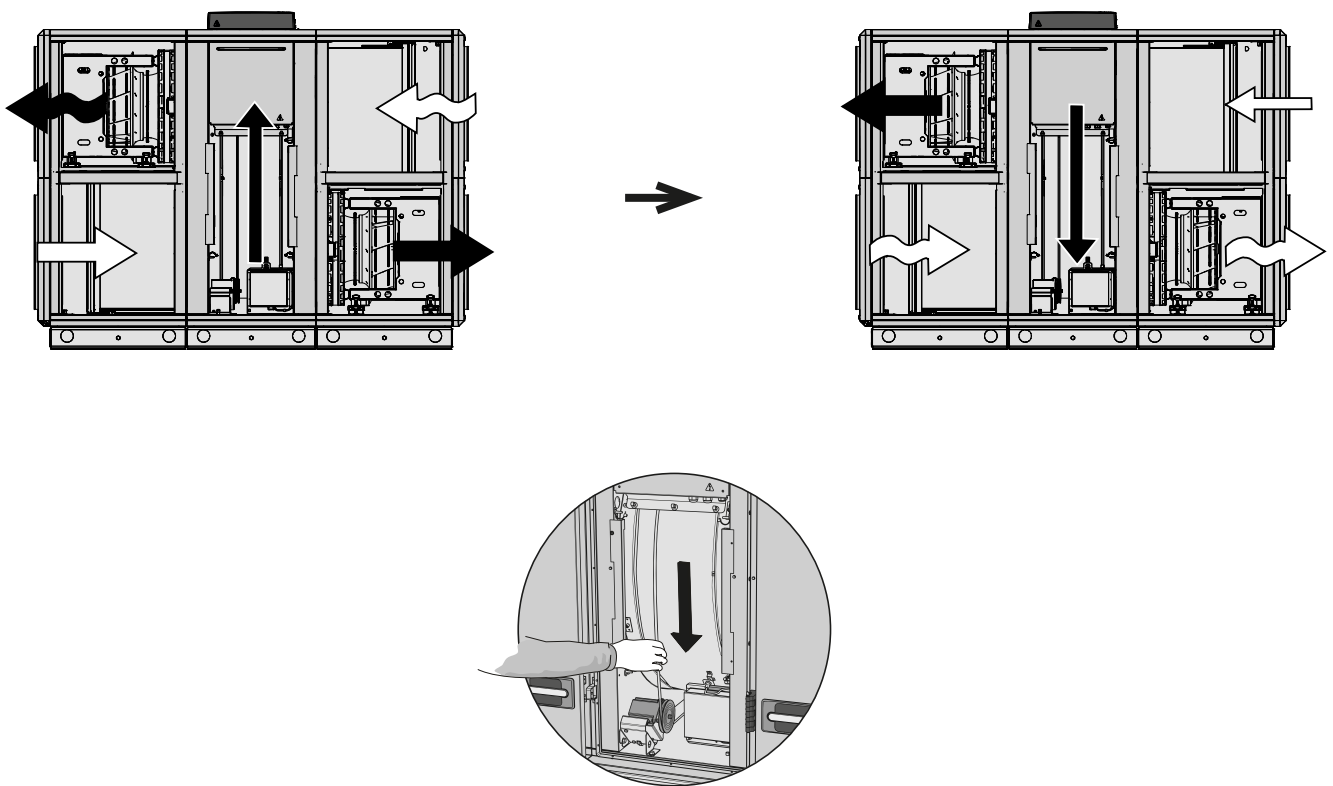

EN - See also special instructions for heat exchanger controls.  
SE - Se också särskild instruktion för värmeväxlarstyrning.  
DK - Se også separat vejledning til varmevekslerstyrning.  
FI - Katso myös erityisiä ohjeita lämmönvaihtimen ohjaukselle.

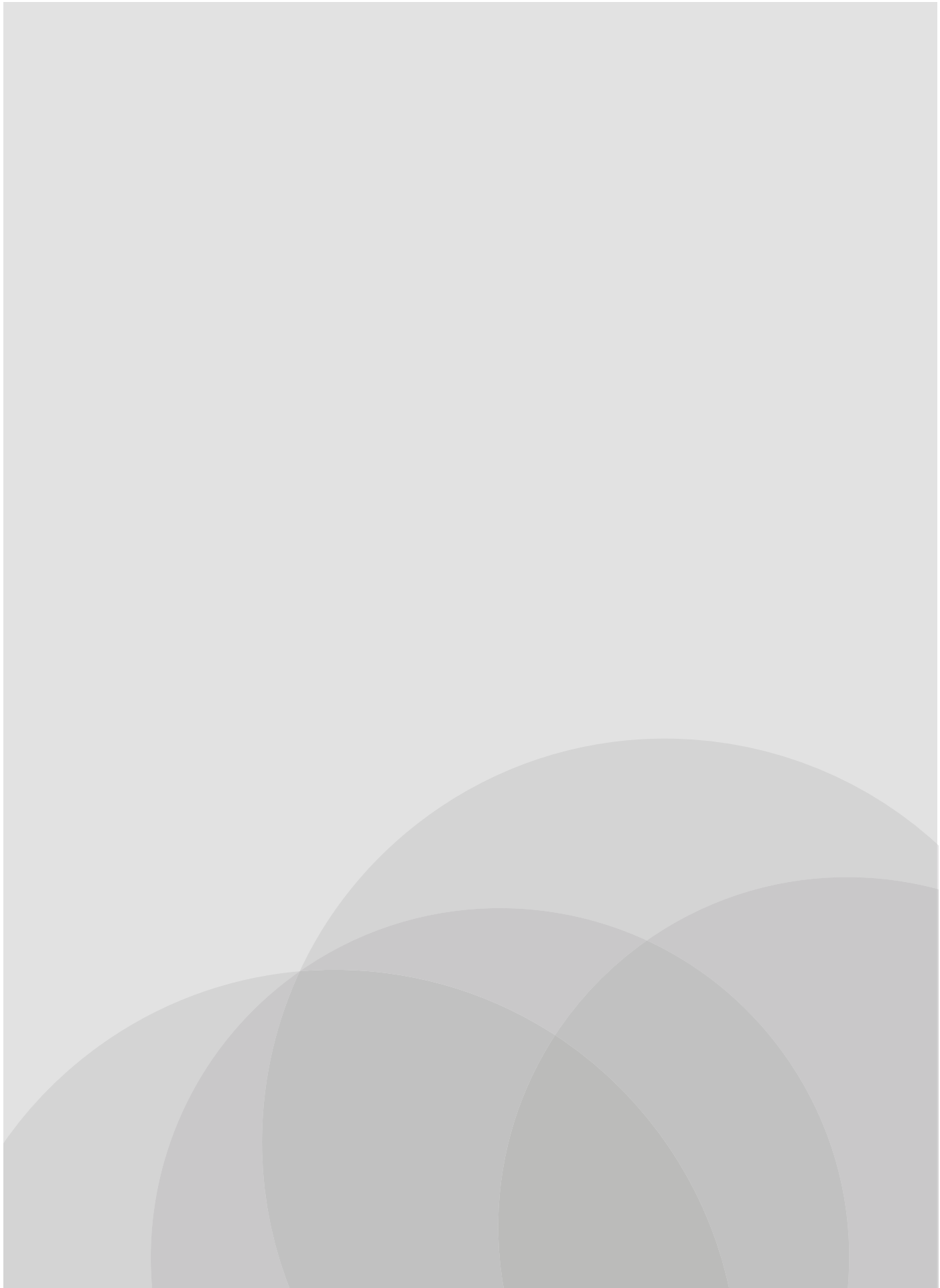

Specifications are subject to alteration without notice.